



VCompact RNE series

Технические характеристики

По вопросам продаж и поддержки обращайтесь:

Архангельск (8182)63-90-72

Астана +7(7172)727-132

Белгород (4722)40-23-64

Брянск (4832)59-03-52

Владивосток (423)249-28-31

Волгоград (844)278-03-48

Вологда (8172)26-41-59

Воронеж (473)204-51-73

Екатеринбург (343)384-55-89

Иваново (4932)77-34-06

Ижевск (3412)26-03-58

Казань (843)206-01-48

Калининград (4012)72-03-81

Калуга (4842)92-23-67

Кемерово (3842)65-04-62

Киров (8332)68-02-04

Краснодар (861)203-40-90

Красноярск (391)204-63-61

Курск (4712)77-13-04

Липецк (4742)52-20-81

Магнитогорск (3519)55-03-13

Москва (495)268-04-70

Мурманск (8152)59-64-93

Набережные Челны (8552)20-53-41

Нижний Новгород (831)429-08-12

Новокузнецк (3843)20-46-81

Новосибирск (383)227-86-73

Орел (4862)44-53-42

Оренбург (3532)37-68-04

Пенза (8412)22-31-16

Пермь (342)205-81-47

Ростов-на-Дону (863)308-18-15

Рязань (4912)46-61-64

Самара (846)206-03-16

Санкт-Петербург (812)309-46-40

Саратов (845)249-38-78

Смоленск (4812)29-41-54

Сочи (862)225-72-31

Ставрополь (8652)20-65-13

Тверь (4822)63-31-35

Томск (3822)98-41-53

Тула (4872)74-02-29

Тюмень (3452)66-21-18

Ульяновск (8422)24-23-59

Уфа (347)229-48-12

Челябинск (351)202-03-61

Череповец (8202)49-02-64

Ярославль (4852)69-52-93

сайт: www.ciat.nt-rt.ru | эл. почта: cta@nt-rt.ru



Vertical package air conditioners



Cooling capacity: 11,6 to 72,6 kW
Heating capacity: 11,7 to 75,2 kW

Scroll compressor

Compact vertical

Centrifugal fans

Ducted aspiration and discharge

Options for air renewal

DESCRIPTION

The VCompact NE heat pumps and cooling unit are compact air to air units, monobloc of vertical compact construction, designed to be installed indoors, safe from external damages, with access registers to fans, cooling circuit and electrical panel by means of easily removable panels.

These units are suitable for commercial and industrial applications where the availability of space allows its installation.

They offer the advantage of its vertical construction, and options which include elements of air renovation in only one unit.

All of the units are tested and checked in factory.

RANGE

- VCompact NE series, 1 cooling circuit, 1 scroll compressor, 4 models: 80 / 90 / 120 / 160.
- VCompact NE series, 2 cooling circuits, 2 scroll compressors, 3 models: 180 / 240 / 320.

SERIES

VCompact RNE series

Air to air cooling units of vertical compact construction.

VCompact INE series

Reversible air to air heat pump units of vertical compact construction.

OPERATING LIMITS

Inlet air conditions		Cooling	Heating
Indoor coil	Minimum	14°C WB	10°C
	Maximum	21°C WB	27°C
Outdoor coil	Minimum	12°C ①	-7°C WB ②
	Maximum	43°C	15°C WB

① With control of the condensation pressure operating up to -10°C.

② When the outdoor temperature is usually below 5°C WB it is recommended installing a support element.

UNIT CONFIGURATION

Casing

- Casing made of galvanised steel metal with polyester paint dried to the furnace and thermal insulation. Self-supporting frame.

Outdoor circuit

- Centrifugal fan(s) with coupling by pulleys and belts. Electric motor(s) with tensioner, class F, IP55 and internal thermal protection. Turbines with an impeller of front-curved blades. Greased spherical bearings, with no maintenance required. Optionally, high available pressure.
- Protection grille(s) of the fan supply outlet(s).
- Condensates drain pan.
- Copper pipe and aluminium fins coil.

Indoor circuit

- Centrifugal fan with coupling by pulleys and belts. Electric motor with tensioner, class F, IP55 and internal thermal protection. Turbines with an impeller of front-curved blades. Greased spherical bearings, with no maintenance required. Optionally, high available pressure.
- Reusable air filter.
- Condensates drain pan.
- Copper pipe and aluminium fins coil.

Cooling circuit

- Scroll compressor(s) assembled over shock absorbers. Thermal protection.
- Thermostatic expansion valve with outdoor pressure external equalisation.
- Anti-acid dehydrator filter.
- Four-way valve for cycle inversion (VCompact INE series).
- Crankcase heater.

Protections

- High and low pressure pressostats.
- Compressor discharge temperature control.
- Main door switch.
- Automatic switch in the control circuit.
- Magnetothermic protection switches for the compressor(s) and fan(s) motor power line.
- Fan thermal protection.

Electric panel

- Complete and fully wired electrical panel.
- Main earth connection.
- Compressor(s) and fan motor contactors.

AVANT / AVANT+ electronic control

- **AVANT version:** models 80 to 160
- **AVANT+ version:** models 180 to 320

This control is basically comprised of a control board, a TCO user terminal installed on the electric panel, a graphic terminal pGD1 (optional) and sensors.

The pGD1 terminal (optional) facilitates the initial scheduling of the unit, the modification of the operating parameters and the description of the alarms produced. This terminal can be installed on the electric panel, instead of TCO terminal, or with remote connection.



TCO terminal



pGD1 terminal

Main functions:

- Selection of the operating mode: COOLING, HEATING, AUTOMATIC, FAN and DEHUMIDIFICATION.
- Modification of the setpoint.
- Permanent control of the operating parameters.
- View of the values measured by the probes.
- Timing of the compressors
- Defrosting management (in heat pump units), with possibility of intelligent defrosting.
- Anti-fire safety.
- Control of the outlet temperature.
- Compressor discharge temperature control by probe.
- Compensation of the setpoint in accordance with the outdoor temperature.
- Timer and weekly programming.
- Failure diagnosis and main alarm.
- Counters of the number of starts and operating hours of the unit's components.

Optional functions:

- Humidity control.
- Management of thermal free-cooling (with AVANT & AVANT+ versions).
- Management of enthalpic or thermoenthalpic free-cooling (only with AVANT+ version).
- Control of the minimum opening of the outdoor air damper.
- Control of the auxiliary electrical heaters.
- Proportional control of a hot water auxiliary coil.
- Detection of clogged filters and management of air flow controller.
- Connection to a centralised technical management system (BMS) for supervision.

OPTIONS

Outdoor environment

- Copper tube and copper fins coil, or aluminum polyurethane-coated fins.
- Condensation pressure control with damper.

Confort / heating

- Electrical heaters support. With this option, the air flow controller is included.
- Hot water support coil. With this optional the thermostat anti-frost is obligatory as safety system, in case of exterior assembly or with free-cooling, if the unit works with low outdoor temperatures.

Acoustic

- Compressor acoustic isolation.

Safety

- Differential pressostat for the detection of clogged filters.
- Differential pressostat for control of air flow.
- Smoke detecting station.
- Air quality probe for installation in the environment to enable measuring CO2 and/or volatile compounds.

Installation

- Switchable supply and return position of the indoor circuit.
- Assemblies with mixing box and free-cooling (see enclosed diagram).
- Antivibration mounts made of rubber.

Control / communication

- Change to AVANT+ version (models 80 to 160).
- Options of the AVANT & AVANT+ control.

Assemblies with mixing box and free-cooling

- 2 dampers (motorised): outdoor air intake with damper, interlocked with return damper.
- 3 dampers (motorised): centrifugal return fan.

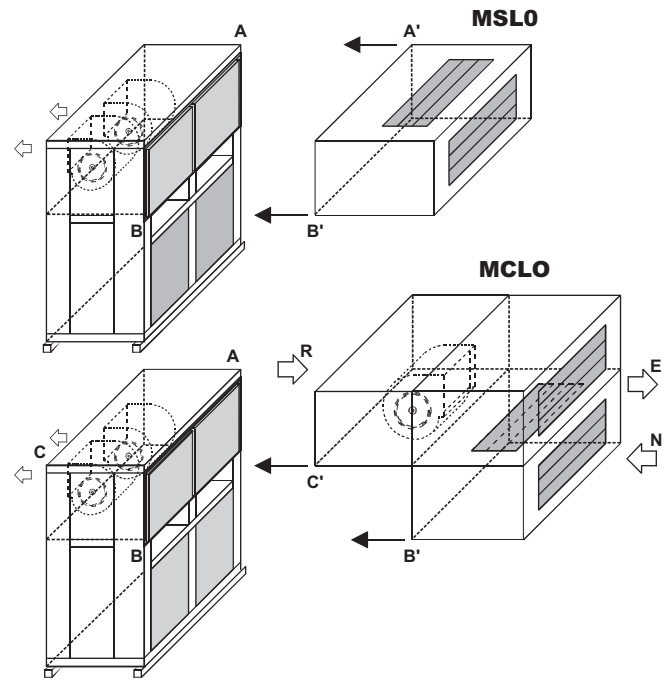

Air circulation

- R = Return
- E = Extraction
- N = New inlet

Denomination

- Mwxy
- S = Simple (2 dampers)
 - C = Centrifugal return fan
 - 0 = Standard
 - L = Flow in "L"

DIFFERENT ASSEMBLIES

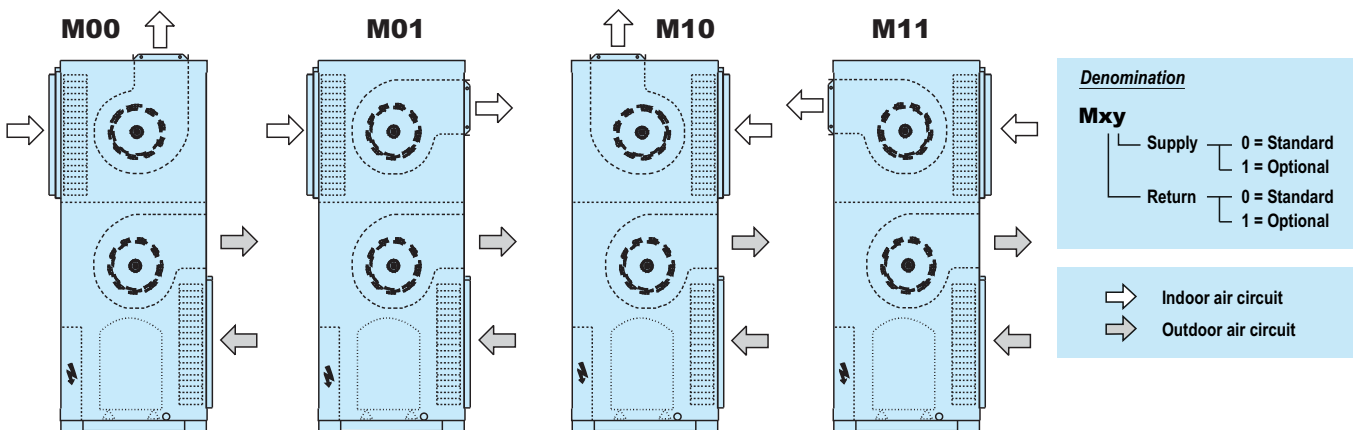

Denomination

Mxy

- Supply
 - 0 = Standard
 - 1 = Optional
- Return
 - 0 = Standard
 - 1 = Optional

- ↗ Indoor air circuit
- ↘ Outdoor air circuit



Vertical package air conditioners

VCompact NE

TECHNICAL CHARACTERISTICS

VCompact NE		80	90	120	160	180	240	320	
Cooling capacities	Cooling capacity ① (kW)	17,9	19,3	26,8	34,8	38,6	53,6	69,6	
	Power input ③ (kW)	7,3	8,3	11,2	14,2	16,6	22,7	28,5	
	EER performance	2,5	2,3	2,4	2,5	2,3	2,4	2,4	
Heating capacities	Heating capacity ② (kW)	18,4	20,2	27,8	36,5	40,4	55,6	73,0	
	Power input ③ (kW)	6,5	7,3	9,5	12,0	14,6	19,3	24,1	
	COP performance	2,8	2,8	2,9	3,0	2,8	2,9	3,0	
Outdoor circuit fan	Nominal air flow (m³/h)	6.500	7.000	10.000	12.200	14.000	20.000	24.400	
	Available static pressure (mm.w.c)	7	7	13	14	7	13	14	
	Type	Centrifugal							
	Number	1				2			
	Motor output (kW)	1,1	1,5	2,2	3,0	1,5	2,2	3,0	
	Speed (r.p.m.)	630	680	699	644	680	699	644	
Indoor circuit fan	Nominal air flow (m³/h)	4.000	4.600	6.000	7.000	9.200	12.000	14.000	
	Available static pressure (mm.w.c)	10	7	12	9	6	12	12	
	Type	Centrifugal							
	Number	1							
	Motor output (kW)	0,75	0,75	1,1	1,5	1,5	3	3	
	Speed (r.p.m.)	941	725	927	644	747	839	697	
Compressor	Type	Scroll							
	Compressor number	1				2			
	Circuit number	1				2			
Electrical characteristics	Electrical power supply	400 V / III ph / 50 Hz (±10%)							
	Power supply	3 wires + ground + neutral							
Maximum absorbed current	Compressor (A)	17	17	29	29	2 x 17	2 x 29	2 x 29	
	Outdoor fan (A)	2,7	3,6	5,0	6,9	2 x 3,6	2 x 5	2 x 6,9	
	Supply fan (A)	2,1	2,1	2,7	3,6	3,6	6,9	6,9	
	Total (A)	21,8	22,7	36,7	39,5	44,8	74,9	78,7	
Refrigerant	Type	R-407C							
	Global warming potential (GWP) ④	1.744							
	Charge (kg)	4,0	5,0	6,4	7,3	10,0	13,0	15,0	
	Environment impact (tCO2eq)	7,0	8,7	11,2	12,7	17,4	22,7	26,2	
Dimensions	Length (mm)	1.174	1.174	1.440	1.440	2.161	2.704	2.704	
	Width (mm)	885	885	934	934	885	934	934	
	Height (mm)	1.840	1.840	2.015	2.015	1.840	2.015	2.015	
Weight	RNE (kg)	395	402	485	538	725	930	1.048	
	INE (kg)	410	417	504	558	755	956	1.088	
Ø Condensate evacuation		3/4"							

① Cooling capacity given for indoor temperature conditions 27°C, 50% RH and 35°C outdoor temperature.

② Heating capacity given for indoor temperature conditions 20°C and 6°C WB outdoor temperature.

③ Total power input by compressor and motorised fans under nominal conditions.

④ Climatic warming potential of a kilogram of fluorinated greenhouse gas in relation to a kilogram of carbon dioxide over a period of 100 years.

DENOMINATION

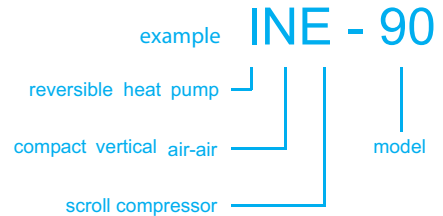
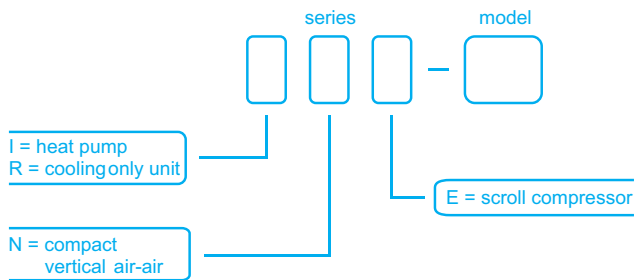

ELECTRICAL CONNECTIONS

No.	VCompact NE	80 to 320
1	Power supply 400 III ($\pm 10\%$)	3 + N + GND
2	TCO user terminal connection (by default it's installed on the electric panel) ①	2 wires for power 230 Vac + 1 shielded cable for communication type AGW20 / 22 (1braided pair + drainwire + shielding)
3	pGD1 maintenance terminal connection	6-wire standard telephone cable (RJ12 connector)
4	Remote on / off (optional)	2 wires
5	Main alarm signal (optional)	2 wires
6	Electrical heater security thermistor (optional)	2 wires (per stage)

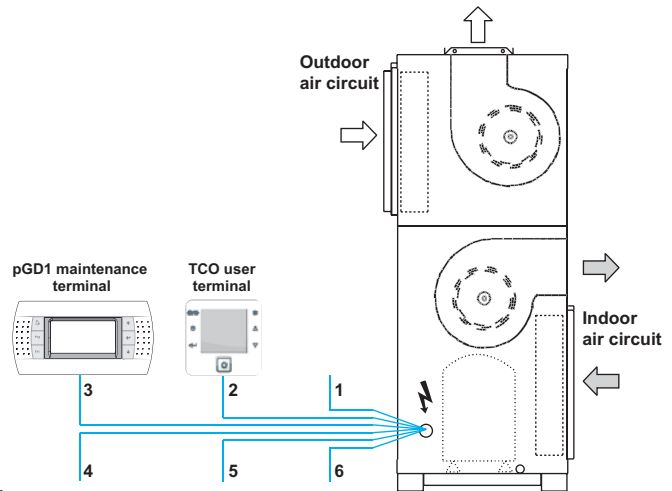

① Is necessary that the terminal uses the same power supply that the control board.

POWER LEVEL AND SOUND PRESSURE LEVEL dB(A)

A) The **sound power level** in the **outdoor fan** to be taken into account for the silencer calculation:

VCompact NE	80	90	120	160	180	240	320
dB(A)	74,4	76,3	81,9	83,6	79,3	84,9	86,6

B) The **sound power level** in the **indoor fan** to be taken into account for the silencer calculation:

VCompact NE	80	90	120	160	180	240	320
dB(A)	79,4	75,1	77,5	80,2	77,8	83,1	79,0

C) The **sound pressure level** of the **unit**, with the return and outlet connections ducted, measured at a distance of 5 meters, in open field, the directivity at 2 and 1.5 meters from the earth is:

VCompact NE	80	90	120	160	180	240	320
dB(A)	65,7	67,9	71,4	74,0	70,8	75,2	76,0

Note: The sound pressure level depends on the installation conditions and, as such, it only indicated as a guide.

ELECTRICAL HEATER (OPTION)

Important: with this option, the air flow controller is included.

Electric heater assembly in 1 stage, except for 24 kW to 36 kW with assembly in 2 stages.

For another stages configuration, it is necessary to check if it is possible and the price.

Available capacities

VCompact NE	Power supply	400 V / III ph / 50 Hz								
	Power output (kW)	3	6	9	12	15	18	24	30	36
80 / 90 / 120 / 160	Current (A)	4,3	8,7	13	17,3	21,7	26	unavailable		
180 / 240 / 320	Current (A)	4,3	8,7	13	17,3	21,7	26	34,6	43,4	52,0

Note: in models with centrifugal return fan it is to check available power output.

Frame for assembly of the electrical heater on supply fan

VCompact NE	Power output	Dimensions (mm)		
		A	B	C
80 (1 supply outlet)	3 to 6 kW (1 row)	150	432	341
	9 to 12 kW (2 rows)	262	432	341
	15 to 18 kW (2 rows)	262	482	443
90 (1 supply outlet)	3 to 9 kW (1 row)	150	482	443
	12 to 18 kW (2 rows)	262	482	443
120 / 160 (1 supply outlet)	3 to 12 kW (1 row)	150	432	341
	15 to 18 kW (2 rows)	262	432	341
180 / 240 (2 supply outlets)	3 to 18 kW (1 row)	150	482	443
	24 to 36 kW (2 rows)	262	482	443
320 (2 supply outlets)	3 to 18 kW (1 row)	150	547	443
	24 to 36 kW (2 rows)	262	547	443

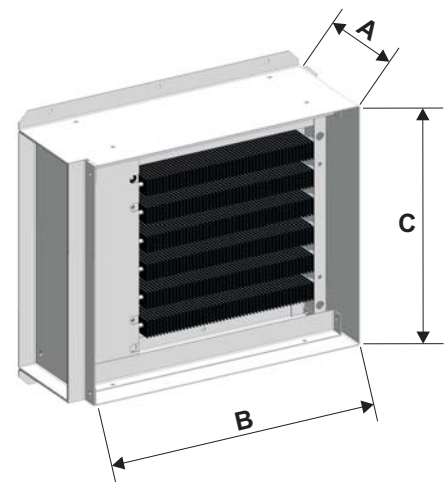

This frame is designed with side access for maintenance purposes.

In models with two supply outlet (two frames), the electrical heaters are distributed as symmetrically as possible between both frames.

AUXILIARY HOT WATER COILS (OPTION)

Two-row hot water coils for mounting in duct, except for 120 and 160 models for mounting inside of the unit

VCompact NE	80	90	120	160	180	240	320
Nominal air flow (m ³ /h)	4.000	4.600	6.000	7.000	9.200	12.000	14.000
Heating capacity (water 80/60°C and inlet air 21°C) (kW)	33	35	51	56	74	103	112
Air pressure drop (mm.w.c.)	3,7	4,6	3,5	4,5	4,6	3,5	4,5
Water pressure drop (m.w.c.)	1,0	1,2	1,2	1,4	1,2	1,4	1,6
Ø Hydraulic connections: I/O	1 1/4"	1 1/4"	1 1/2"	1 1/2"	1 1/2"	2"	2"



Vertical package air conditioners

VCompact NE

COOLING CAPACITY (kW)

Outdoor temperature 35°C

RNE INE	Flow m³/h	Indoor air temperature											
		23 °C / 50 % HR			25 °C / 50 % HR			27 °C / 50 % HR			29 °C / 50 % HR		
		Pft	Pfs	Pa	Pft	Pfs	Pa	Pft	Pfs	Pa	Pft	Pfs	Pa
80	3.200	14,5	13,8	6,1	15,8	14,2	6,0	17,2	15,0	5,9	18,2	15,4	5,9
	4.000	15,1	14,1	6,2	16,5	14,7	6,1	17,9	15,5	6,0	18,9	15,9	6,0
	4.400	15,4	15,3	6,3	16,8	16,0	6,4	18,2	15,7	6,1	19,2	16,1	6,1
90	3.600	16,1	15,1	6,5	17,4	15,7	6,6	18,6	16,2	6,6	19,9	16,6	6,6
	4.600	16,7	15,6	6,6	18,1	16,2	6,6	19,3	16,7	6,6	20,7	17,1	6,7
	4.800	17,0	15,8	6,7	18,4	16,4	6,7	19,6	16,9	6,7	21,0	17,3	6,7
120	4.800	22,6	18,4	9,0	24,2	18,9	9,0	25,9	19,5	9,0	27,6	19,9	9,1
	6.000	23,5	21,1	9,0	25,1	21,7	9,0	26,8	22,3	9,1	28,5	22,8	9,1
	6.600	23,7	22,3	9,0	25,3	23,0	9,0	27,0	23,6	9,1	28,7	24,2	9,2
160	5.800	29,6	23,4	11,4	31,7	24,1	11,5	33,9	24,6	11,6	36,1	25,1	11,7
	7.000	30,5	25,8	11,5	32,6	26,6	11,6	34,8	27,3	11,7	37,0	27,9	11,8
	7.300	30,8	26,6	11,5	32,9	27,4	11,6	35,1	28,1	11,7	37,3	28,7	11,8
180	7.200	32,2	30,2	13,1	34,8	31,4	13,2	37,2	32,4	13,2	39,8	33,2	13,3
	9.200	33,4	31,2	13,2	36,2	32,4	13,2	38,6	33,4	13,2	41,2	34,2	13,4
	9.600	34,0	31,6	13,4	36,8	32,8	13,4	39,2	33,8	13,4	42,0	34,6	13,4
240	9.600	45,2	36,8	18,0	48,4	38,8	18,0	51,8	39,0	18,1	55,2	39,8	18,2
	12.000	47,0	42,2	18,1	50,2	43,4	18,1	53,6	44,6	18,2	57,0	45,6	18,3
	13.200	47,4	44,6	18,1	50,6	46,0	18,1	54,0	47,2	18,2	57,4	48,4	18,4
320	11.600	59,2	46,8	22,9	63,4	48,2	23,0	67,8	49,2	23,2	72,2	50,2	23,4
	14.000	61,0	51,6	23,1	65,2	53,2	23,2	69,6	54,6	23,4	74,0	55,8	23,6
	14.600	61,6	53,2	23,1	65,8	54,8	23,2	70,2	56,2	23,4	74,6	57,4	23,6

Pft: Total cooling capacity in kW

Pfs: Sensible cooling capacity in kW

Pa: Compressor power input in kW

Correction coefficients of cooling capacity

Correction coefficients per outdoor temperature variation K1

Outdoor temperature	30°C	32°C	36°C	38°C	40°C	43°C
Coefficient K1	1.07	1.04	0.98	0.96	0.93	0.89

$$PFT = Pft \times K1 \times K2$$

$$PFS = Pfs \times K1 \times K3$$

Correction coefficients per outdoor temperature variation K2 and K3

Relative humidity	40%	50%	60%	70%
Coefficient K2	0.97	1.00	1.05	1.10
Coefficient K3	1.10	1.00	0.92	0.84

Correction coefficients of power input

Correction coefficients per outdoor temperature variation K4

Outdoor temperature	30°C	32°C	36°C	38°C	40°C	43°C
Coefficient K4	0.95	0.98	1.01	1.03	1.05	1.08

$$PA = Pa \times K4 \times K5$$

Correction coefficients per outdoor temperature variation K5

Relative humidity	40%	50%	60%	70%
Coefficient K5	0.97	1.00	1.05	1.10



Vertical package air conditioners

VCompact NE

HEATING CAPACITY (kW)

Indoor temperature 21°C

INE	Flow m ³ /h	Outdoor air temperature											
		-5 °C WB		-2,5 °C WB		0 °C WB		2,5 °C WB		6 °C WB		10 °C WB	
		Pc	Pa	Pc	Pa	Pc	Pa	Pc	Pa	Pc	Pa	Pc	Pa
80	3.200	13,3	5,0	14,2	5,1	15,3	5,2	16,4	5,2	18,3	5,4	20,8	5,6
	4.000	13,4	4,8	14,3	4,9	15,4	5,0	16,5	5,0	18,4	5,2	20,9	5,4
	4.400	13,5	4,7	14,4	4,8	15,5	4,9	16,6	4,9	18,5	5,1	21,0	5,3
90	3.600	15,1	5,3	16,1	5,4	17,2	5,5	18,3	5,7	20,0	5,9	22,6	6,1
	4.600	15,2	5,1	16,2	5,2	17,3	5,3	18,4	5,4	20,2	5,6	22,8	5,7
	4.800	15,3	5,1	16,3	5,1	17,4	5,2	18,5	5,3	20,3	5,5	22,9	5,7
120	4.800	20,2	7,4	21,6	7,5	23,0	7,6	24,9	7,7	27,6	7,8	30,7	7,9
	6.000	20,4	7,1	21,8	7,1	23,2	7,2	25,1	7,3	27,8	7,4	30,9	7,5
	6.600	20,6	6,9	22,0	6,9	23,4	7,0	25,3	7,1	28,0	7,2	31,1	7,3
160	5.800	26,4	9,3	28,2	9,5	30,1	9,6	32,5	9,7	36,2	9,9	40,1	10,2
	7.000	26,7	8,9	28,5	9,1	30,4	9,2	32,8	9,3	36,5	9,5	40,4	9,8
	7.300	26,9	8,7	28,7	8,9	30,6	9,0	33,0	9,1	36,7	9,3	40,6	9,6
180	7.200	30,2	10,7	32,2	10,9	34,4	11,1	36,6	11,4	40,0	11,8	45,2	12,2
	9.200	30,4	10,3	32,4	10,4	34,6	10,6	36,8	10,8	40,4	11,2	44,6	11,5
	9.600	30,6	10,2	32,6	10,3	34,8	10,5	37,0	10,7	40,6	11,1	45,8	11,4
240	9.600	40,4	14,8	43,2	15,0	46,0	15,2	49,8	15,4	55,2	15,6	61,4	15,8
	12.000	40,8	14,2	43,6	14,3	46,4	14,4	50,2	14,6	55,6	14,8	61,8	15,0
	13.200	41,2	13,8	44,0	13,9	46,8	14,0	50,6	14,2	56,0	14,4	62,2	14,6
320	11.600	52,8	18,6	56,4	19,0	60,2	19,2	65,0	19,4	72,4	19,8	80,2	20,4
	14.000	53,4	17,8	57,0	18,2	60,8	18,4	65,6	18,6	73,0	19,0	80,8	19,6
	14.600	53,8	17,4	57,4	17,8	61,2	18,0	66,0	18,2	73,4	18,6	81,2	19,2

Pc: Total heating capacity in kW

Pa: Compressor power input in kW

Correction coefficients of heating capacity

Correction coefficients due to indoor temperature variation K1 and K2

Indoor temperature	17°C	19°C	21°C	23°C	25°C	27°C
Coefficient K1	1.06	1.02	1.00	0.97	0.95	0.97
Coefficient K2	0.96	0.98	1.00	1.02	1.04	1.06

PC = Pc x K1

PA = Pa x K2

DIMENSIONS SCHEMES

VCompact NE - 80 / 90, assembly M00 (mm)

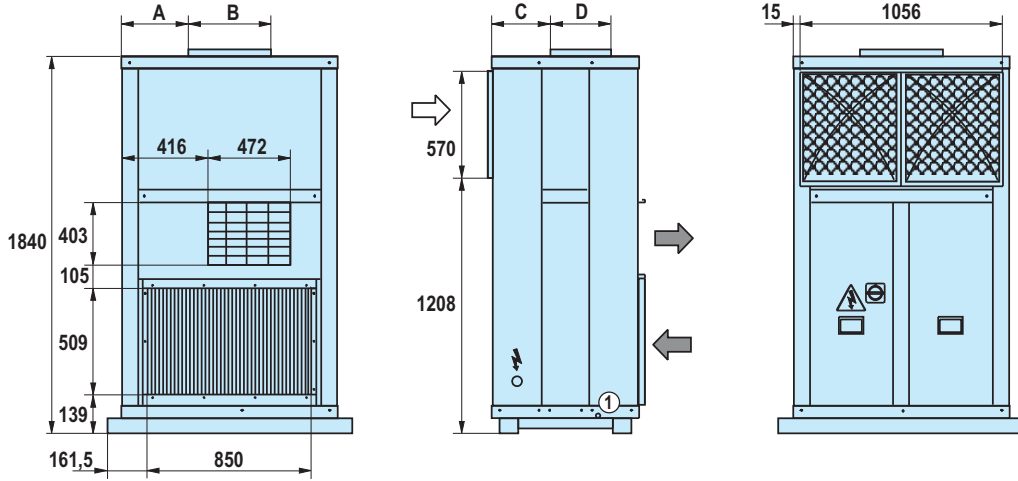

LEYEND

- Outdoor air circuit
- Indoor air circuit
- Electric panel
- Power supply
- Door switch
- Condensate outlet \varnothing 3/4"

Antivibration anchoring: \varnothing 18mm holes

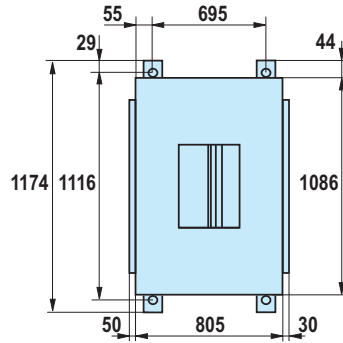

Model	A	B	C	D
80	345.5	337	335.5	295
90	342.5	401	349.5	347

VCompact NE - 80 / 90, assembly M01 (mm)

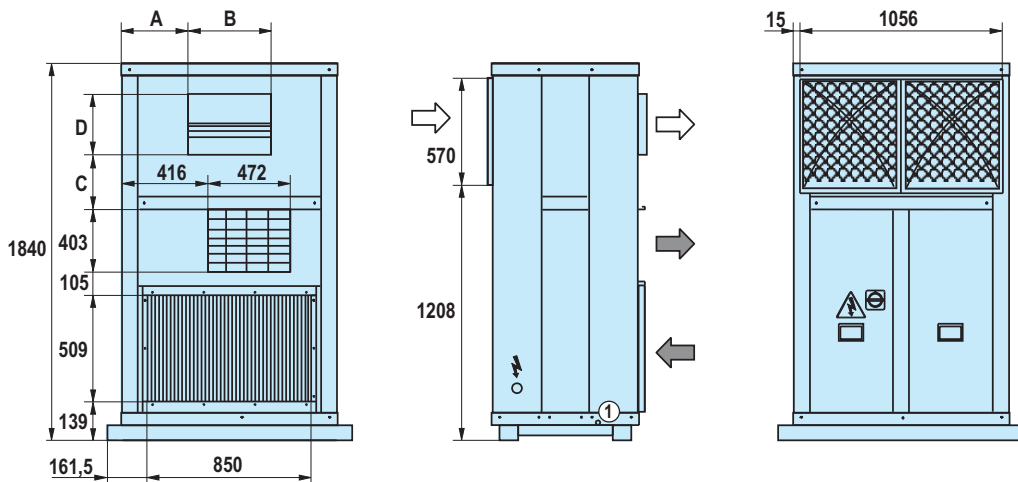

LEYEND

- Outdoor air circuit
- Indoor air circuit
- Electric panel
- Power supply
- Door switch
- Condensate outlet \varnothing 3/4"

Antivibration anchoring: \varnothing 18mm holes

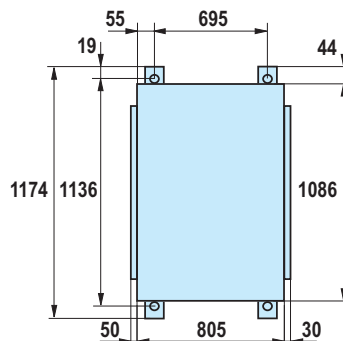

Model	A	B	C	D
80	374.5	337	162	295
90	342.5	401	188	347

VCompact NE - 120 / 160, assembly M00 (mm)

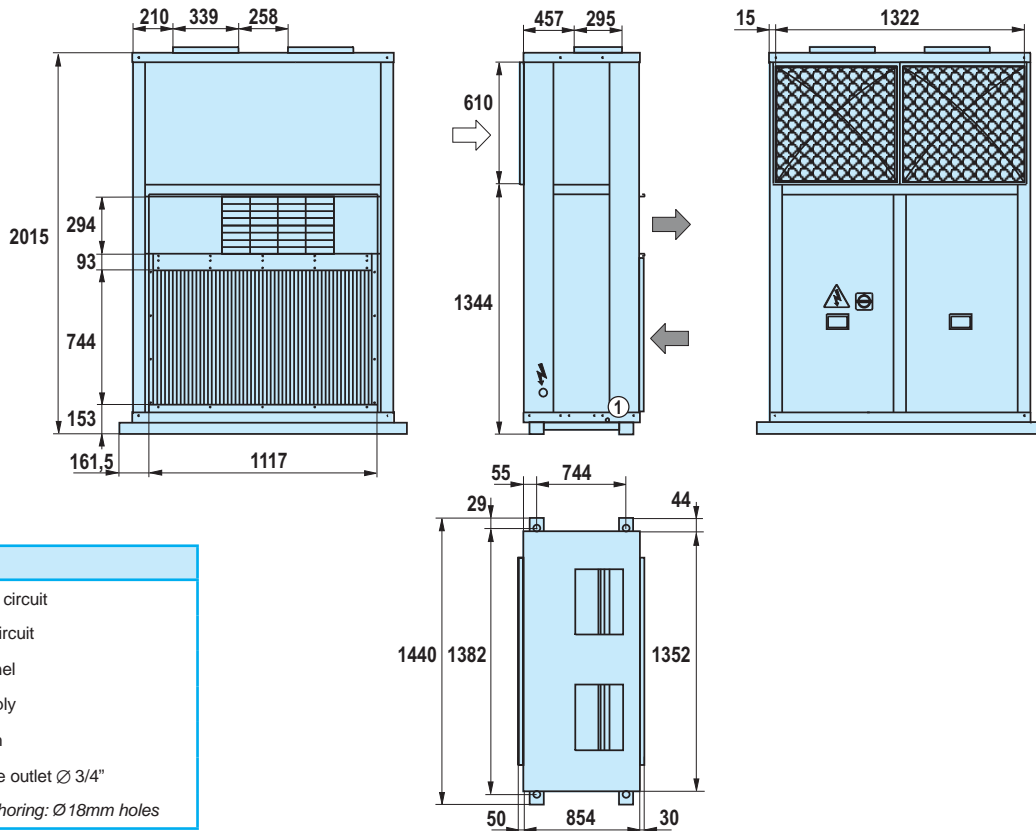

VCompact NE - 120 / 160, assembly M01 (mm)

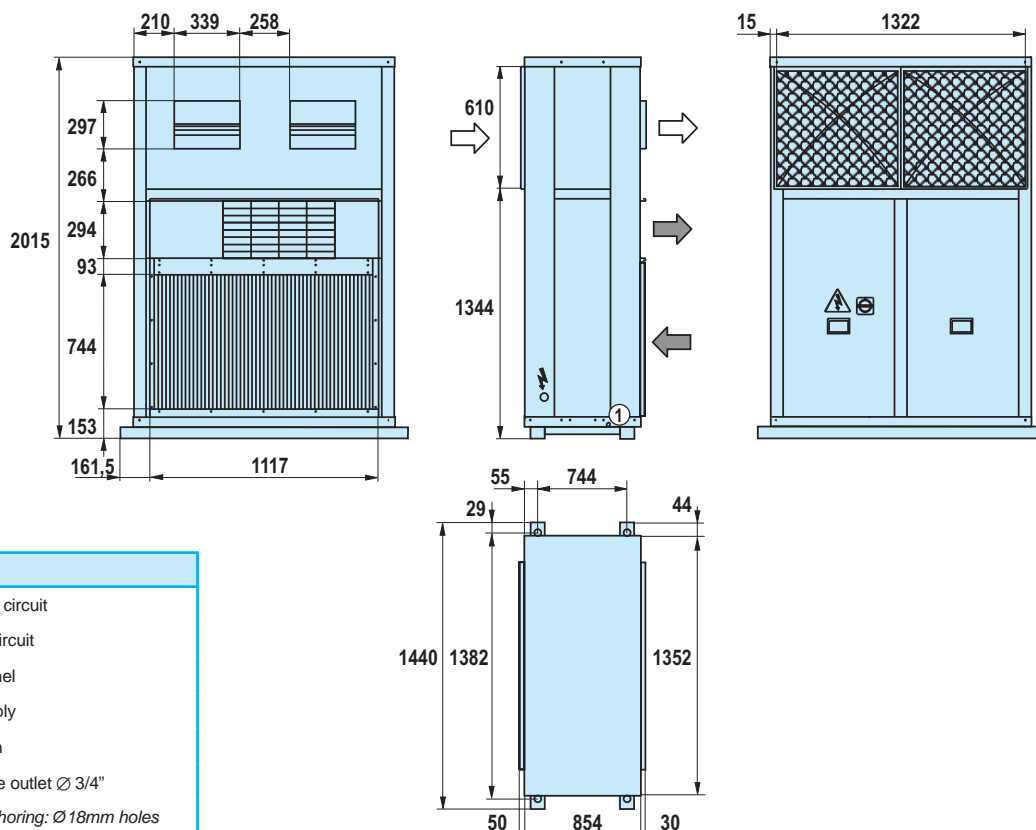

VCompact NE - 180, assembly M00 (mm)

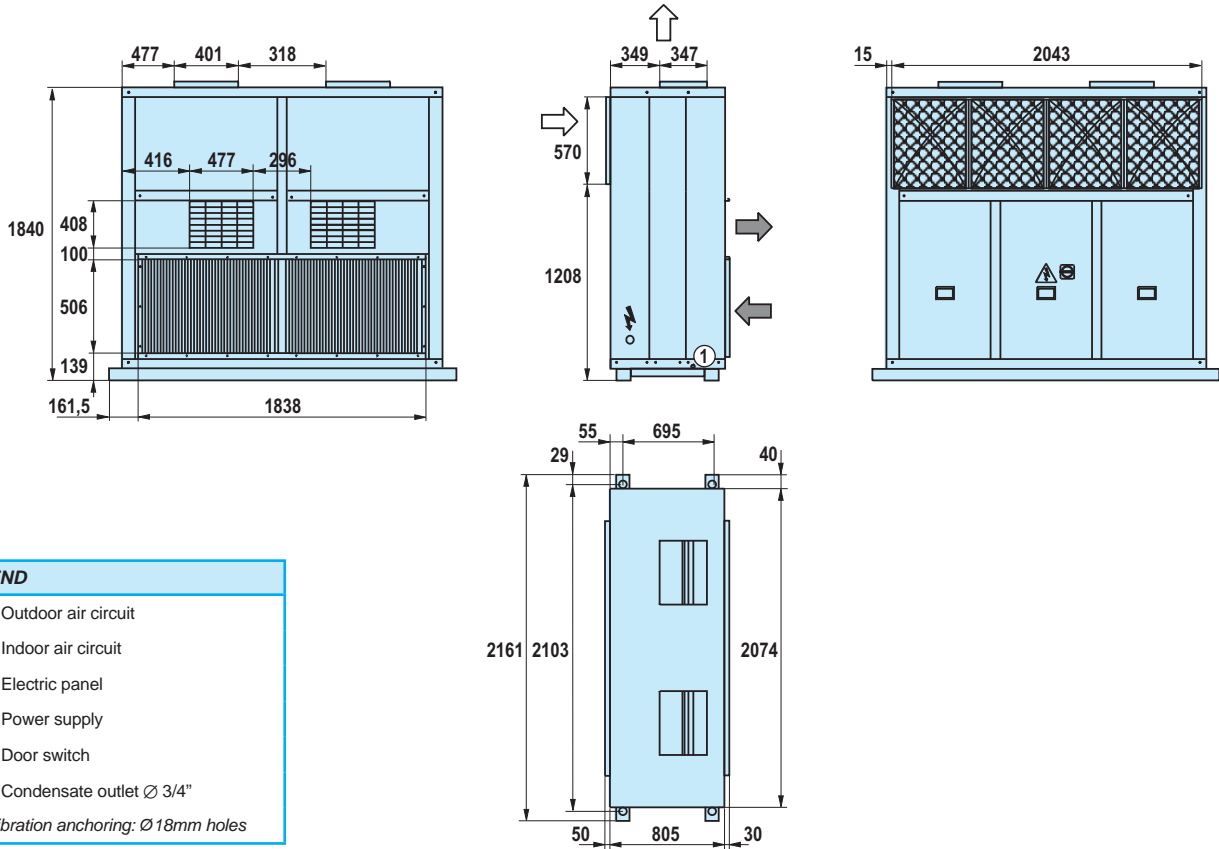

VCompact NE - 180, assembly M01 (mm)

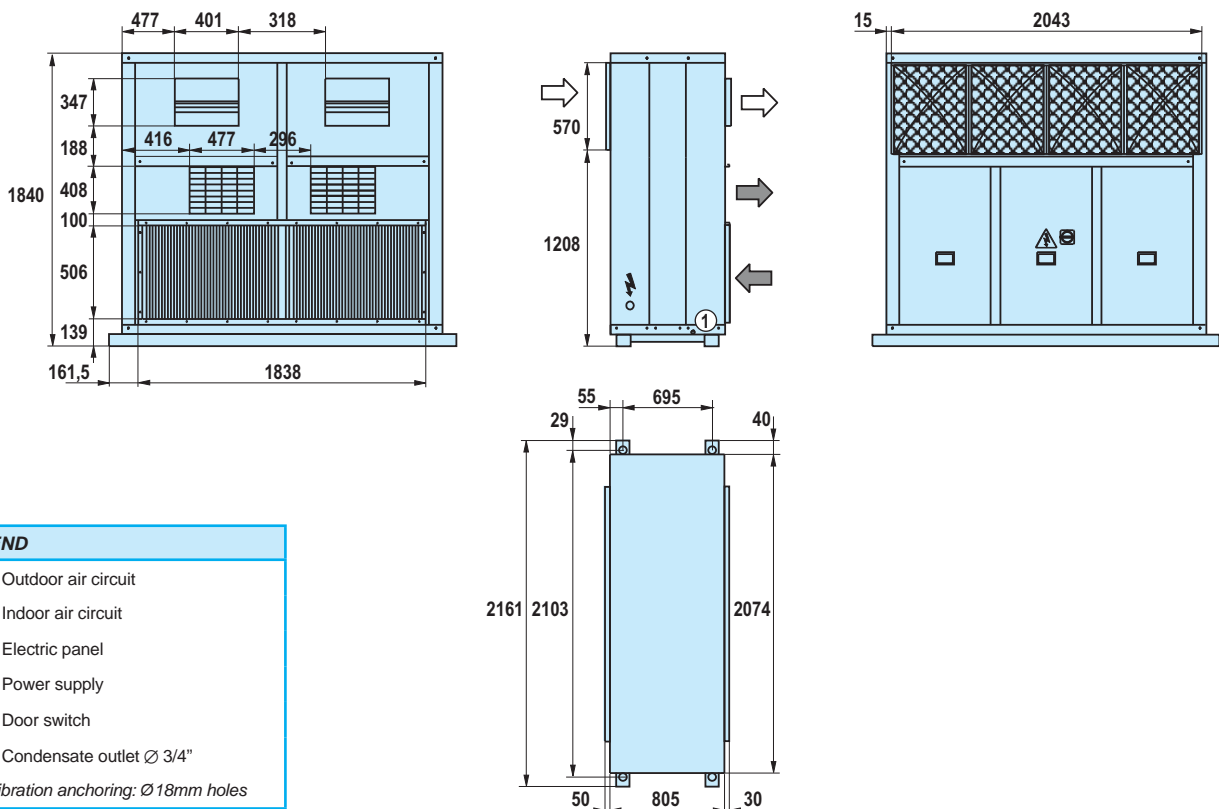

VCompact NE - 240 / 320, assembly M00 (mm)

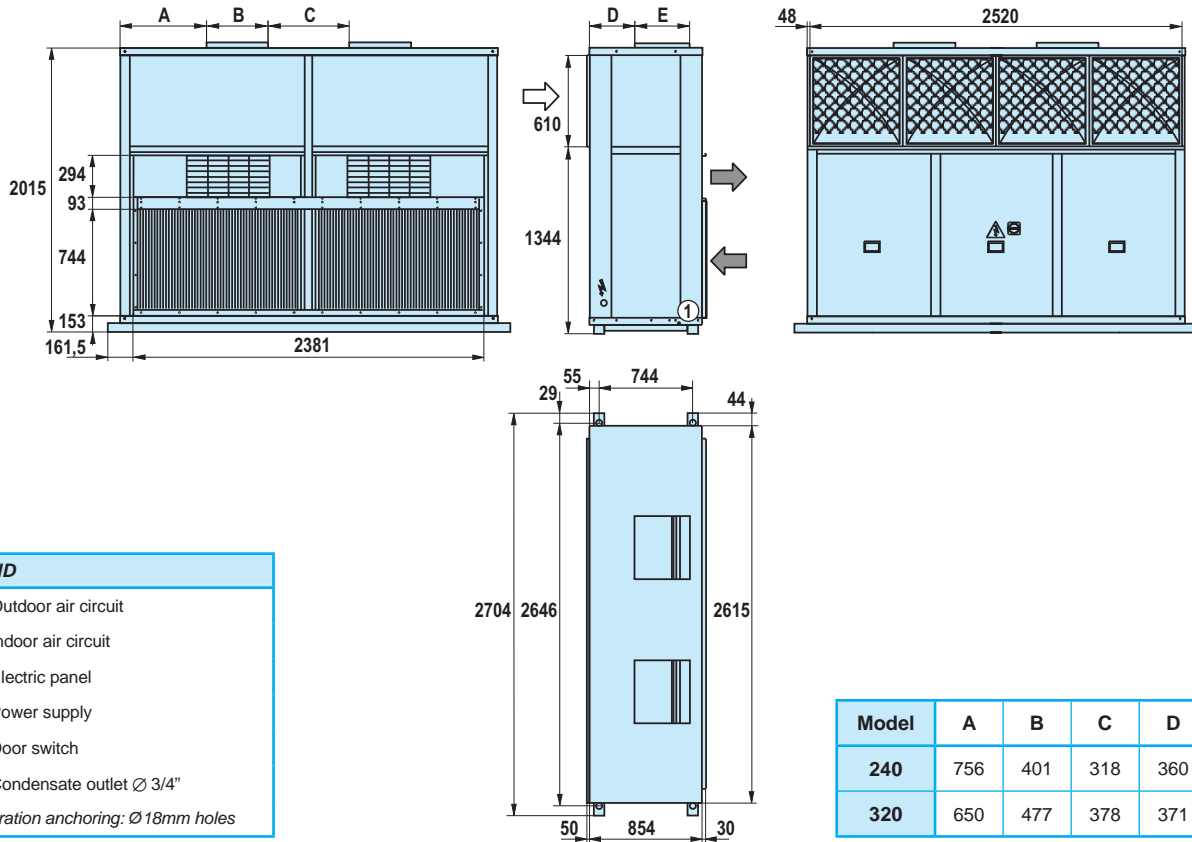

VCompact NE - 240 / 320, assembly M01 (mm)

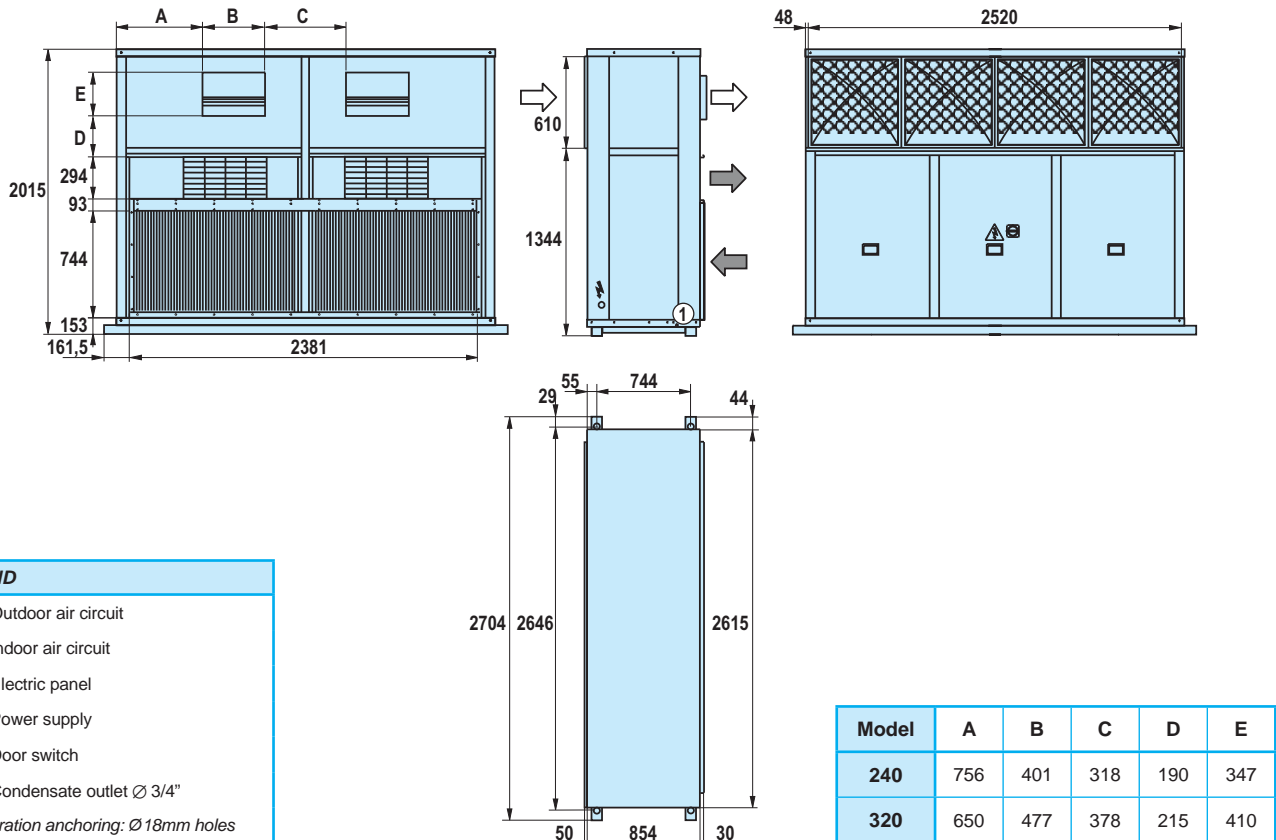



По вопросам продаж и поддержки обращайтесь:

Архангельск (8182)63-90-72

Астана +7(7172)727-132

Белгород (4722)40-23-64

Брянск (4832)59-03-52

Владивосток (423)249-28-31

Волгоград (844)278-03-48

Вологда (8172)26-41-59

Воронеж (473)204-51-73

Екатеринбург (343)384-55-89

Иваново (4932)77-34-06

Ижевск (3412)26-03-58

Казань (843)206-01-48

Калининград (4012)72-03-81

Калуга (4842)92-23-67

Кемерово (3842)65-04-62

Киров (8332)68-02-04

Краснодар (861)203-40-90

Красноярск (391)204-63-61

Курск (4712)77-13-04

Липецк (4742)52-20-81

Магнитогорск (3519)55-03-13

Москва (495)268-04-70

Мурманск (8152)59-64-93

Набережные Челны (8552)20-53-41

Нижний Новгород (831)429-08-12

Новокузнецк (3843)20-46-81

Новосибирск (383)227-86-73

Орел (4862)44-53-42

Оренбург (3532)37-68-04

Пенза (8412)22-31-16

Пермь (342)205-81-47

Ростов-на-Дону (863)308-18-15

Рязань (4912)46-61-64

Самара (846)206-03-16

Санкт-Петербург (812)309-46-40

Саратов (845)249-38-78

Смоленск (4812)29-41-54

Сочи (862)225-72-31

Ставрополь (8652)20-65-13

Тверь (4822)63-31-35

Томск (3822)98-41-53

Тула (4872)74-02-29

Тюмень (3452)66-21-18

Ульяновск (8422)24-23-59

Уфа (347)229-48-12

Челябинск (351)202-03-61

Череповец (8202)49-02-64

Ярославль (4852)69-52-93

сайт: www.ciat.nt-rt.ru | эл. почта: cta@nt-rt.ru